

**BOARD REPORT**

**NO.** 25-023

**DATE** February 20, 2025

**C.D.** 15

**BOARD OF RECREATION AND PARK COMMISSIONERS**

**SUBJECT:** BANNING MUSEUM – GIFT AGREEMENT WITH FRIENDS OF BANNING PARK CORPORATION FOR THE REHABILITATION OF THE BANNING MUSEUM HISTORIC WELL; CATEGORICAL EXEMPTION FROM THE PROVISIONS OF THE CALIFORNIA ENVIRONMENTAL QUALITY ACT (CEQA) PURSUANT TO ARTICLE 19, SECTION 15331 [PROJECTS LIMITED TO MAINTENANCE, REPAIR, STABILIZATION, REHABILITATION, RESTORATION, PRESERVATION, CONSERVATION OR RECONSTRUCTION OF HISTORICAL RESOURCES IN A MANNER CONSISTENT WITH THE SECRETARY OF THE INTERIOR’S STANDARDS FOR THE TREATMENT OF HISTORIC PROPERTIES WITH GUIDELINES FOR PRESERVING, REHABILITATING, RESTORING, AND RECONSTRUCTING HISTORIC BUILDINGS (1995), WEEKS AND GRIMMER] OF CALIFORNIA CEQA GUIDELINES

* B. Aguirre	<u>BA</u>	M. Rudnick	_____
C. Stoneham	_____	C. Santo Domingo	_____
B. Jones	_____	N. Williams	_____

  
 \_\_\_\_\_  
 General Manager

Approved \_\_\_\_\_ Disapproved \_\_\_\_\_ Withdrawn \_\_\_\_\_

**RECOMMENDATIONS**

1. Approve a proposed one-year Gift Agreement (Agreement) with Friends of Banning Park Corporation (Organization) for a historic well rehabilitation project (Project) which consists of the historic well and a designated construction staging area in proximity to the well, subject to coordination with RAP Staff (Premises) at the Banning Museum located at 401 East M Street Wilmington, CA 90744 (Museum), in substantially the form attached to this Report as Attachment 1 to this Report, subject to the approval of the City Attorney as to form;
2. Accept the completed Project as a gift from the Organization to RAP, funded through private donations made to the Organization in the collective value of \$274,000;
3. Direct the Board of Recreation and Park Commissioners (Board) Secretary to transmit the proposed Agreement to the City Attorney for review and approval as to form;
4. Authorize the Board President and Secretary to execute the Agreement subsequent to all necessary approvals;
5. Determine that the Project is categorically exempt from the provisions of the California

## BOARD REPORT

PG. 2 NO. 25-023

Environmental Quality Act (CEQA) pursuant to Article 19, Section 15331 [Projects limited to maintenance, repair, stabilization, rehabilitation, restoration, preservation, conservation or reconstruction of historical resources in a manner consistent with the Secretary of the Interior's Standards for the Treatment of Historic Properties with Guidelines for Preserving, Rehabilitating, Restoring, and Reconstructing Historic Buildings (1995), Weeks and Grimmer] of California CEQA Guidelines and direct staff to file a Notice of Exemption (NOE) with the Los Angeles County Clerk and the Governor's Office of Land Use and Climate Innovation;

6. Authorize RAP's Planning, Maintenance and Construction Branch (PMC), upon the Board's approval of this Report, to issue a Right of Entry Permit (ROE) to the Organization and their selected contractor to allow access to the Premises for the Project;
7. Authorize RAP's Chief Accounting Employee to prepare a check to the Los Angeles County Clerk in the amount of \$75.00 for the purpose of filing an NOE; and,
8. Authorize RAP staff to make any necessary technical changes consistent with the RAP Board's intent in approving this Report and proposed Agreement.

### SUMMARY

RAP manages and operates the Banning Museum, a historical site that includes a residence built in 1864, surrounding 20 acres of parkland, including Stagecoach Barn, Exhibit Hall, Research Hall, Rose Garden, and parkland located at 401 East M Street Wilmington, CA 90744 (collectively, Museum). The residence was built by Phineas Banning, an entrepreneur, founder of the City of Wilmington, and "the father of the Port of Los Angeles." Subsequent generations resided at the Banning residence until 1925, and it was acquired by the City in 1927. Over the years, the property fell into disrepair, but Friends of Banning Park Corporation restored the space to its original state, and it is now a living history museum operated by RAP, allowing visitors to experience how the Banning family lived in the 19th century through guided tours and educational programs for elementary school children. The residence has been designated a City Historic-Cultural Monument and a State Historic Landmark, and it is also included in the National Register of Historic Places. RAP has an on-site Museum Director and support staff who offer guided tours to the public Tuesday through Sunday as well as educational programs for schools such as a living history program.

Friends of Banning Park Corporation (Organization) is a 501(c)(3) non-profit organization founded in 1974 to support the Museum's educational and cultural programs as well as ongoing restoration and conservation. The Organization, also known as Friends of Banning Museum, was spearheaded by the great-granddaughter of Phineas Banning, Nancy Banning Call. The Organization is dedicated to preserving the history of the Banning Residence and their mission is to ensure that the Banning Family's story is not lost to history and that it remains a source of inspiration for others to follow their hopes and dreams.

## BOARD REPORT

PG. 3 NO. 25-023

The proposed Project consists of the restoration of a damaged existing, non-functional historic well to match the original height, as well as an accessible path to view the well, to be maintained by RAP in perpetuity. The well was originally constructed in the 1870s in order to try and solve the problem of the lack of a steady water supply in Wilmington at that time. Phinneas Banning proposed that the well be dug on his own property in order to tap into the groundwater supply. At the time that the well was built, it was deemed the “largest well in California,” at 25 feet in diameter and 40 feet depth. It was also very successful, as it yielded 500,000 gallons of water daily, solving the water supply issues that Wilmington had been dealing with until that point.

The Project is funded by the Organization through private donations valued at \$274,000. The Organization will contract with Spectra Historic Construction (Contractor) for the rehabilitation of the historic well pursuant to plans and specifications designed in consultation with the Department of City Planning’s Office of Historic Resources, approved by RAP Planning, Construction, and Maintenance (PMC) Staff, and attached hereto as Exhibit B to Attachment 1. Further detail on the historic well construction and restoration is included in the Letter from Spectra Historic Construction included in Attachment 1 as Exhibit C. Upon Project completion and post-construction inspection by RAP PMC Staff, RAP shall maintain the Premises in perpetuity. On-site signage may be added in the future describing the well and providing historical background (signage is not part of this Project).

### TREES AND SHADE

This Proposed Agreement will not have any impact on existing trees or shade at the Premises.

### ENVIRONMENTAL IMPACT

The proposed Project consists of reconstruction of an historical resource in a manner consistent with the Secretary of the Interior's Standards for the treatment of historic properties<sup>1</sup>.

According to the parcel profile report retrieved on September 3, 2024, this site is not within a coastal or liquefaction zone. It is located in a methane zone, but since the site is outdoors the proposed Project is not expected to increase the risk of methane seepage, there is no reasonable possibility that the proposed Project may impact an environmental resource of hazardous or critical concern or have a significant effect due to unusual circumstances. No other known projects would involve cumulatively significant impacts, and no future projects would result from the proposed Project. As of September 3, 2024, the State Department of Toxic Substances Control (DTSC) (Envirostor at [www.envirostor.dtsc.ca.gov](http://www.envirostor.dtsc.ca.gov)) and the State Water Resources Control Board (SWRCB) (Geotracker at <https://geotracker.waterboards.ca.gov/>) have not listed the Project site or any contaminated sites near the Project area (within 1,000 feet). According to the Caltrans Scenic Highway Map, there is no scenic highway located within – or adjacent to – the proposed Project or within its site. Furthermore, the proposed Project is within the premises of the Banning

---

<sup>1</sup> Weeks & Grimmer (1995). Treatment of Historic Properties with Guidelines for Preserving, Rehabilitating, Restoring and Reconstructing Historic Buildings. Available at <https://www.nps.gov/orgs/1739/secretary-standards-treatment-historic-properties.htm>

## BOARD REPORT

PG. 4 NO. 25-023

Residence, which is listed in the National Register of Historic Places (#71000160) and designated as a California Historical Resource (#147 and #21215) and a City of Los Angeles Historic Cultural Monument (HCM #25). The proposed Project has been designed with the intent to restore the historical nature of the well. Preserving all of the original extant materials, restoring the historic height of the wall and restoring the original grade around the near perimeter of the well wall will restore much more of the character of the original well wall and conform to the Secretary of the Interior's Standards for Rehabilitation; the Project will not cause a substantial adverse change in the significance of any historical resource.

Based on this information, RAP staff recommends that the Board determines that the proposed Project is categorically exempt from the provisions of the California Environmental Quality Act (CEQA) pursuant to Article 19, Section 15331 of California CEQA Guidelines. Staff will file a Notice of Exemption with the Los Angeles County Clerk and the Governor's Office of Land Use and Climate Innovation upon Board's approval.

### FISCAL IMPACT STATEMENT:

The approval of this Project will have no immediate fiscal impact on RAP's General Fund, as the Organization will be solely responsible for costs and expenses associated with the Project. Future maintenance of the well will be part of the regular budgetary process for the Banning Museum and may be supported by the RAP General Fund and/or Friends of Banning Park Corporation.

This Report was prepared by Priya Macwan, Management Analyst, Sustainability and Partnership Sections and Joel Alvarez, Senior Management Analyst II, Partnership Section.

### List of Attachments:

1. Proposed Agreement and Exhibits

**AGREEMENT  
BETWEEN CITY OF LOS ANGELES  
AND  
FRIENDS OF BANNING PARK CORPORATION  
FOR REHABILITATION OF THE  
BANNING MUSEUM HISTORIC WELL**

This AGREEMENT (“AGREEMENT”) is entered into as of \_\_\_\_\_, 2025, (“COMMENCEMENT DATE”) by and between the City of Los Angeles, a municipal corporation acting by and through its Board of Recreation and Park Commissioners (“CITY”), and Friends of Banning Park Corporation, a 501(c)(3) nonprofit corporation (“ORGANIZATION”), for a historic well rehabilitation project (“PROJECT”) at the Banning Museum. CITY and ORGANIZATION may be referred to herein individually as “PARTY” and/or collectively as “PARTIES.”

WHEREAS, CITY, through its Department of Recreation and Parks (“RAP”), owns, maintains and operates real property referred to as The Banning Museum, located at 401 East M Street Wilmington, CA 90744, which is a historical site that includes a residence built in 1864 and surrounding 20 acres of parkland, including stagecoach barn, gardens and grounds (collectively, “MUSEUM”). The residence has been designated a City Historic-Cultural Monument and a State Historic Landmark, and is listed on the National Register of Historic Places. The specific PROJECT location, within the MUSEUM, consists of the historic well and a designated construction staging area in proximity to the well, subject to coordination with RAP Staff (“PREMISES”) which are depicted in the Site Plan attached hereto and incorporated herein by reference as Exhibit A; and,

WHEREAS, ORGANIZATION is a nonprofit corporation founded in 1974 to support the educational and cultural programs as well as ongoing restoration and conservation at the MUSEUM; and,

WHEREAS, the PROJECT consists of the restoration of a damaged existing, non-functional historic well to match the original height of the well, as well as the installation of an accessible path to view the well, to be maintained by RAP in perpetuity; and,

WHEREAS, the PROJECT shall be funded by the ORGANIZATION through private donations in the value of \$274,000 and donated to CITY; and,

WHEREAS, ORGANIZATION will be contracting with Spectra Historic Construction for the rehabilitation of the historic well pursuant to the plans and specifications created in consultation with the Department of City Planning and approved by RAP, and attached hereto as Exhibit B. Historic background and details of well restoration work are included in the Letter from Spectra Historic Construction (“CONTRACTOR”) to RAP attached hereto and incorporated herein by reference as Exhibit C; and,

WHEREAS, the PROJECT scope of work has been reviewed and approved by the RAP Planning, Construction and Maintenance Branch (“PCM”), RAP is amenable to authorizing such improvement of the PREMISES and accepts the donation from the ORGANIZATION for the rehabilitation of the PREMISES, as more fully described herein;

and,

WHEREAS, CITY wishes to accept this donation upon PROJECT completion, subject to the performance of a post-construction inspection by PCM, and to exclusively operate and maintain the PREMISES after the completion of the PROJECT, pursuant to the terms and conditions of this AGREEMENT; and,

WHEREAS CITY, through its Board of Recreation and Parks Commissioners (“BOARD”), has approved this AGREEMENT at the BOARD meeting held on date, 2025 (Board Report No. XX-XXX).

NOW THEREFORE, in consideration of the foregoing, the anticipated benefits to the public, and the terms and conditions set forth herein and the performance thereof, PARTIES hereby agree as follows:

1. **PROJECT Implementation.** In consideration of the anticipated benefits to the public, the sufficiency of which is mutually acknowledged, CITY grants to ORGANIZATION by this AGREEMENT, the authority to rehabilitate the Banning Museum Historic Well, which includes the restoration of the damaged existing, non-functional historic well to match the original height of the well, as well as the installation of an accessible path to view the well.

The benefit to the public shall be the added educational purpose of the PROJECT, which may, in the future, be supported by additional signage describing the well and providing historical background to the effect detailed in the Letter from the CONTRACTOR attached hereto as Exhibit C, subject to any required signage approvals at RAP’s discretion, depending on the scope and nature of such signage. Upon the completion of the PROJECT, RAP shall assume all maintenance responsibility of the PREMISES. The PROJECT to be completed by CONTRACTOR, at the sole expense of ORGANIZATION under the terms and conditions of this AGREEMENT, includes, but is not necessarily limited, to the following Scope of Work pursuant to approved Plans and Specifications (Exhibit B):

- a. Restore historic brick well wall to original height.
- b. Remove any non-original or deteriorated brick.
- c. Match historic brick as close as possible in dimensions, color and texture.
- d. Analyze mortar and ensure compatible mortar mix in color, aggregate, hardness and tooling.
- e. Remove a vent addition within the well and level the stepped concrete infill to eliminate the step.
- f. Excavate a four-foot wide area around the perimeter of the well to restore the original grade for enough width to view the entire elevation of the well wall and to partially restore the original setting.
- g. Add a bench retaining wall, ramp and steps for access, and seating for educational opportunities.
- h. Ensure that trees within the area of work are protected in consultation and coordination with the RAP Forestry Division.

PROJECT implementation is slated to commence as soon as possible. Subject to the termination and other provisions set forth in this AGREEMENT, ORGANIZATION shall contract with Spectra Historic Construction (“CONTRACTOR”) to manage the implementation of the PROJECT, including the coordination of work with any other contractors and/or subcontractors (collectively, “CONTRACTORS”) hired by CONTRACTOR. The PROJECT, as described by Exhibit B, shall be performed in accordance with the following guidelines and requirements. All costs associated with the implementation of the PROJECT shall be the responsibility of ORGANIZATION and ORGANIZATION agrees to obtain prior written approval from RAP for any subsequently proposed modifications, additions, or changes to the Scope of Work.

ORGANIZATION and CONTRACTOR shall be the lead agency(s) with respect to overseeing the completion of the PROJECT, including the completion of environmental clearances and any other permits and approvals required by law (including, but not limited to, any requirements arising from or related to the MUSEUM residence’s designation as a City Historic-Cultural Monument and a State Historic Landmark or inclusion in the National Register of Historic Places). All costs and filing of documents required for obtaining said clearances, approvals and authorizations, shall be borne by ORGANIZATION.

ORGANIZATION, and their agents, representatives, employees and contractors, shall have access to the PREMISES during construction, pursuant to the terms and conditions of a Right of Entry permit (ROE) issued by RAP authorizing access to the PREMISES for purposes of performing the Scope of Work required for the completion of the PROJECT.

Notwithstanding Section 4 below, CITY shall have access to MUSEUM and PREMISES in the performance of normal operations during performance of the Scope of Work associated with the completion of the PROJECT. CITY shall take all necessary precautions to ensure that such access does not interfere with Scope of Work activities.

PARTIES shall jointly approve any and all change orders related to the design and/or PROJECT implementation. ORGANIZATION shall provide CITY advanced notification and copies of all change order requests prior to any approvals or related action. ORGANIZATION agrees to provide CITY with approved “As-Built” plans (if applicable) within thirty days from the Notice of Completion.

2. **PROJECT Completion.** Upon completion of construction, RAP shall conduct a Post-Development Inspection to ensure that the PROJECT has been developed pursuant to the approved Plans and Specifications and in compliance with the terms and conditions of this AGREEMENT.

Following RAP’s acceptance of the completed PROJECT and subsequent to opening of the PROJECT to the public, ORGANIZATION shall have no involvement, whether financial or otherwise, with the use, operation, maintenance, landscaping, repair, insurance, programming or modifications of the PROJECT. The PROJECT shall be maintained by RAP in accordance with established standards.

3. **TERM and Termination.** The term of this AGREEMENT (“TERM”) shall commence upon the COMMENCEMENT DATE stipulated on page one of this AGREEMENT. Except for the continuing obligations of CITY set forth in this AGREEMENT (such as maintenance of the PROJECT), and unless otherwise terminated pursuant to the terms and conditions contained herein, this AGREEMENT shall expire one year from the COMMENCEMENT DATE of this AGREEMENT. Any amendment, extension, or modification to this AGREEMENT shall be executed pursuant to written mutual agreement of PARTIES, with prior approval by the City Attorney and final approval by the Board of Recreation and Park Commissioners (“BOARD”).

- a. Commencement and Expiration. This AGREEMENT shall take effect on the COMMENCEMENT DATE above and shall end upon the expiration of the TERM or the earlier of (i) a written termination notice from RAP or ORGANIZATION to the other, effective after sixty calendar days from the date of issuance due to either an unfavorable PERFORMANCE REVIEW or termination for cause (including any breach or default of the provisions of this AGREEMENT) during the TERM; or, (ii) the date that ORGANIZATION ceases to operate as defined below in Section 2.c.; or, (iii) ORGANIZATION implements the general termination provision described herein.
- b. Termination. In addition to the CITY’s right to terminate this AGREEMENT for an uncured breach or default as set forth in Sections 12 and 13, CITY and ORGANIZATION may terminate this AGREEMENT upon written notice of termination given to the other PARTY no less than sixty days prior to the date of termination. Further, CITY may immediately terminate this AGREEMENT in the event ORGANIZATION ceases to operate as defined below. CITY and ORGANIZATION reserve the right to terminate this AGREEMENT at their sole discretion for convenience, emergency, or necessity.

If CITY or ORGANIZATION should elect to terminate this AGREEMENT, ORGANIZATION agrees to immediately cease all operations and other activity, remove all personal property and equipment and to peacefully surrender the PREMISES to CITY within sixty calendar days of receiving or providing a written notice of termination. If ORGANIZATION fails to remove all its personal property and equipment within said sixty calendar days after termination of this AGREEMENT, CITY, at its option, may remove such property and equipment, in which event ORGANIZATION shall pay to the CITY, upon demand the reasonable cost of such removal, plus the cost of transportation and disposition thereof.

- c. Ceases to Operate. The phrase “ceases to operate” shall mean the first to occur of any of the following: (i) the termination (but not temporary suspension) of ORGANIZATION’s corporate charter or grant of non-profit status, unless the same is reinstated within ninety calendar days after such termination; (ii) a material change in ORGANIZATION’s purposes or function as contained in ORGANIZATION’s corporate charter or grant of non-profit status (“Stated Purposes”); (iii) a material change in the delivery of services by



ORGANIZATION from that described herein; or (iv) the failure of ORGANIZATION to use the PREMISES for any of the PERMITTED USES or any other default of the terms and conditions or other obligations contained in this AGREEMENT, for a consecutive period of ninety calendar days, unless prevented from doing so because of damage, destruction, major repairs or refurbishment of the improvements within the PREMISES, or for reasons beyond ORGANIZATION's control. Under such circumstances, ORGANIZATION shall immediately cease and desist from all use of the PREMISES, and this AGREEMENT shall be deemed terminated upon ORGANIZATION's receipt of such notification of immediate termination from RAP.

4. **Access to PREMISES.** ORGANIZATION and any authorized third-party associated with ORGANIZATION's activities on the PREMISES shall abide by the terms and conditions expressed in this AGREEMENT and the ROE, and shall cooperate fully with CITY and its employees in the performance of their duties. ORGANIZATION shall be responsible for the actions of any third-party involved with the PROJECT on the PREMISES at all times while such third-party is present on the PREMISES, and RAP Maintenance staff shall be made aware by ORGANIZATION of such third-party activities.

The hours and days of the operation and maintenance of the PREMISES are as follows (PERMITTED TIMES):

Monday-Friday: 8:30am-5:00pm  
Saturday-Sunday: 11:30am-5:00pm

ORGANIZATION and CONTRACTOR shall cooperate with RAP personnel and staff on all matters relative to the conduct of RAP operations or any activity, event, and/or special use, including concerns related to parking, traffic, security, and public attendance, on the PREMISES.

Authorized representatives, agents, and employees of RAP shall have the right to enter the PREMISES at any and all times for purposes of conducting maintenance, operations, or other RAP sponsored activities. In no event shall CITY be responsible or liable to ORGANIZATION for any inconvenience, disturbance, or other damage to ORGANIZATION by reason of the performance by CITY of any activities or work in, upon, above, or under the PREMISES, including but not limited to the transport of materials, tools, and/or equipment in, through, above, or underneath the PREMISES, nor shall the same constitute any grounds for any payments or abatement of payments, hereunder.

CITY makes no warranties whatsoever regarding the condition of the PREMISES. ORGANIZATION has inspected the PREMISES and found it suitable for ORGANIZATION's purposes. CITY shall not be liable for any personal injury or damage to property which ORGANIZATION or its guests or invitees may incur (including injury or damage occurring in connection with ORGANIZATION's activities on the PREMISES), regardless of the cause thereof. ORGANIZATION hereby

releases CITY from all such liability, it being the intent of the PARTIES that ORGANIZATION shall maintain adequate insurance to cover any such losses, as required in Section 8 of this AGREEMENT. If a governmental body with jurisdiction over the PREMISES and/or the CITY or RAP determines that a certain activity, or all of the activities, conducted on the PREMISES are material threats to public safety, CITY may immediately suspend and/or terminate ORGANIZATION's right to conduct such activities on the PREMISES by providing written notice to ORGANIZATION of such immediate suspension. Such activities shall remain suspended until they are no longer deemed a threat to public safety, at which time the CITY shall promptly provide written notice to ORGANIZATION of same.

It is understood by PARTIES that the PREMISES is located in a public park and therefore shall not be considered exclusive to the ORGANIZATION, nor shall access to the MUSEUM be restricted to the general public.

**5. PERMITTED USES.** ORGANIZATION shall not expand and/or change the scope of Permitted Uses ("PERMITTED USES") set forth in this Section and AGREEMENT without the prior written approval and consent of the BOARD through an amendment to this AGREEMENT. ORGANIZATION, at its sole cost and expense, shall:

- a. Use the PREMISES solely for the implementation of the PROJECT as described above in Section 1. ORGANIZATION shall be responsible for all costs and expenses related to PROJECT implementation.
- b. Assume sole responsibility for creating and enforcing protocols ensuring all persons participating in the PROJECT and described Scope of Work on the PREMISES comply with applicable CITY, State, and/or Federal protocols for employees, volunteers, contractors and subcontractors engaging in the PERMITTED USES described herein, including maintenance, such as, certifications, licensing, California DOJ background checks, Live Scan fingerprinting, and including but not limited to compliance with California Assembly Bill 506. ORGANIZATION shall, at its sole expense, obtain and maintain information and documentation verifying its compliance with this provision and the results of such compliance and provide such information and documentation to RAP upon request.
- c. Punctually pay or cause to be paid all ORGANIZATION financial obligations incurred in connection with the implementation of the PROJECT as set forth in this AGREEMENT. ORGANIZATION shall discharge or provide for the discharge of all claims authorized or incurred for labor, equipment, materials, and supplies furnished in connection with ORGANIZATION's use of the PREMISES to the extent such claims do not arise due to any CITY action or omission.
- d. Prohibit and prevent the dispensing and/or consumption of beer, wine or other intoxicating liquors (commonly referred to as alcoholic beverages) on the PREMISES.

**6. Performance Requirements and Use Restrictions.** ORGANIZATION shall use and maintain the PREMISES in accordance with the following.

ORGANIZATION shall:

- a. Complete the PROJECT in accordance with the terms and conditions of this AGREEMENT.
  - b. After completion of the PROJECT, ORGANIZATION shall promptly notify RAP, and RAP shall conduct an inspection of the PREMISES. Upon approval by RAP, maintenance of the PREMISES shall be assumed by RAP. ORGANIZATION shall promptly correct any deficiencies associated with the completion of the PROJECT as may be identified by RAP.
  - c. ORGANIZATION will replace any broken or vandalized parts of the well identified by RAP and installed by CONTRACTOR, within 90 days after final inspection. All ORGANIZATION activities as set forth in this AGREEMENT shall comply with applicable RAP standards and regulations.
- 7. Parking.** ORGANIZATION, associated staff, public patrons and/or guests, whether or not involved in ORGANIZATION or PROJECT activities on the PREMISES, shall have the non-exclusive right to park vehicles within any available parking spaces at the MUSEUM on a first-come-first-served basis. If such parking is metered or normally requires a fee, ORGANIZATION, associated staff, public patrons and/or guests shall be required to adhere to established parking requirements. Exclusive or designated parking shall not be allowed, unless previously approved in writing by RAP.
- 8. Insurance.** Before accessing and using the PREMISES under this AGREEMENT, and periodically as required during its TERM, ORGANIZATION shall furnish CITY with evidence of insurance on an annual basis, from firms reasonably acceptable to CITY and approved to do such business in the State of California. ORGANIZATION or any third party providing work or services under this AGREEMENT shall name the City of Los Angeles and its boards, officers, agents, employees, assigns and successors in interest as an additional insured for all required coverage(s), as applicable. ORGANIZATION will ensure that like insurance will be maintained by any such third party. Evidence of required coverage shall be on forms reasonably acceptable to CITY's Risk Manager and shall include the types and minimum limits set forth in Exhibit D attached hereto and incorporated herein by reference.
- a. ORGANIZATION shall maintain all such insurance at its sole cost and expense throughout the TERM of this AGREEMENT. CITY may, by applying generally accepted risk management principles, change the required amounts and types of insurance to be effective at the renewal date of the insurance then in effect by giving ORGANIZATION sixty calendar days written notice, provided that such amounts and/or types shall be reasonably available to ORGANIZATION.
  - b. If any of the required insurance contains aggregate limits or applies to other operations of ORGANIZATION outside of this AGREEMENT, ORGANIZATION

shall give CITY written notice of any incident, occurrence, claim, settlement or judgment against such insurance that in ORGANIZATION's best judgment may diminish the protection such insurance affords CITY within thirty calendar days of the knowledge of same. ORGANIZATION shall further restore such aggregate limits or shall provide other replacement insurance for such aggregate limits within sixty calendar days of the knowledge of same.

- c. If an insurance company elects to (i) cancel insurance before the stated expiration date, (ii) declines to renew in the case of a continuous policy, (iii) reduces the stated limits other than by impairment of an aggregate limit or (iv) materially reduces the scope of coverage, thereby affecting CITY's interest, ORGANIZATION shall provide CITY at least thirty calendar days prior written notice of such intended election by the insurance company, or ten calendar days prior written notice if such cancellation is for non-payment of premium.

Such notice shall be sent by receipted delivery addressed as follows:

City Administrative Officer, Risk Management  
200 North Main Street, Room 1240, City Hall East  
Los Angeles, California 90012

Or to such address as CITY may specify by written notice to ORGANIZATION.

- d. ORGANIZATION's failure to procure and maintain the required insurance shall constitute a material breach of this AGREEMENT under which CITY may either (i) provide ORGANIZATION five calendar days written notice of such failure, upon receipt of which ORGANIZATION shall have five calendar days to cure such failure or CITY shall have the right to terminate the AGREEMENT or, (ii) at its discretion, pay to procure or renew such insurance to protect CITY's interest. ORGANIZATION agrees to reimburse CITY for all money so paid.
  - e. Self-insurance programs and self-insured retention in insurance policies are subject to separate approval by CITY upon review of evidence of ORGANIZATION's financial capacity. Additionally, such programs or retention must provide CITY with an equivalent protection from liability.
- 9. Indemnification.** Except for the active negligence or willful misconduct of CITY, or any of its boards, officers, agents, employees, assigns and successors in interest, ORGANIZATION shall defend, indemnify and hold harmless CITY and any of its boards, officers, agents, employees, assigns, and successors in interest from and against all lawsuits and causes of action, claims, losses, demands and expenses, including, but not limited to, (i) attorney's fees (both in house and outside counsel) and cost of litigation (including all actual litigation costs incurred by CITY, including but not limited to, costs of experts and consultants), (ii) damages or liability of any nature whatsoever, (iii) for death or injury to any person, including ORGANIZATION's employees and agents, or (iv) damage or destruction of any property of either party hereto or of third parties, arising in any manner by reason of an act, error, or omission by ORGANIZATION, its subcontractors, or their boards, officers, agents, employees,

assigns, and successors in interest. The rights and remedies of CITY provided in this Section shall not be exclusive and are in addition to any other rights and remedies provided by law or under this AGREEMENT. This Section will survive expiration or termination of this AGREEMENT.

ORGANIZATION is aware of the condition of the PREMISES and accepts the PREMISES in its present condition, and agrees to abide by all health and safety regulations and orders. ORGANIZATION has carefully reviewed this document, understands its contents, and signs it voluntarily, without being subject to coercion.

- 10. Publicity.** Should there be the need, CITY and ORGANIZATION agree to cooperate and coordinate with respect to the nature, text, and timing of any press release or public announcement(s) concerning the existence of this AGREEMENT, the use of the PREMISES or promotion of the PROJECT or construction of any additional improvements on the PREMISES in connection with this AGREEMENT or PROJECT, except as may be legally required by applicable laws, regulations, or judicial order. Such cooperation and coordination shall occur prior to the release of any such press release or public announcement(s). PARTIES agree to notify each other in writing prior to the release or use of any such press release, public announcement, marketing or promotion of the PREMISES prior to implementation with respect to the ORGANIZATION's use of the PREMISES. Further, any press release, public announcement, marketing materials, or brochures prepared by either CITY or ORGANIZATION shall appropriately acknowledge the contributions of both PARTIES and shall be subject to prior approval by RAP before release.

To the extent stipulated in any grant agreement, with respect to the PROJECT and the use of the PREMISES in connection thereto, CITY and ORGANIZATION shall duly notify any grantors, and each other, prior to any public or media event publicizing the accomplishments funded by any grant agreement, and shall provide the opportunity for attendance and participation by representatives. Further, CITY and ORGANIZATION shall coordinate the scheduling and organization of any public or media event to provide the opportunity for attendance and participation by officials and/or representatives of both CITY and ORGANIZATION, including elected officials and public officials. Similarly, any document, written report, or brochure prepared by either CITY or ORGANIZATION, in whole or in part, with respect to the use of the PREMISES in connection thereto, shall contain any acknowledgements required under any grant agreement.

- 11. Signage.** No signs or banners of any kind will be displayed by ORGANIZATION unless previously approved in writing by RAP and the BOARD when required pursuant to RAP policy and protocol(s), and/or the RAP General Manager or his or her designee. RAP may require removal or refurbishment, at ORGANIZATION's expense, of any sign previously approved by RAP and installed, or caused to be installed, by ORGANIZATION.

- 12. Breach or Default by ORGANIZATION.** The following occurrences constitute events of breach or default of this AGREEMENT: ORGANIZATION materially fails in the performance of any provision or condition of this AGREEMENT, such as failure to

maintain required insurance coverage, failure to comply with applicable legal requirements, or failure to fulfill the obligation to operate, maintain and repair the PREMISES as specified herein. ORGANIZATION's attempt to assign rights or obligations under this AGREEMENT without CITY's prior written consent shall also constitute an event of breach or default.

**13. Breach or Default by ORGANIZATION – CITY's Remedies.** Upon the occurrence of one or more events of breach or default by ORGANIZATION, CITY may, at its election and without waiving any right to select any other remedy provided in this Section or elsewhere in this AGREEMENT, initiate any of the following:

- a. Notice to Cure Breach or Default. CITY may issue a written notice of breach or default to ORGANIZATION, and if ORGANIZATION does not cure said breach or default within thirty calendar days of receipt of said notice, CITY may, by delivering a second written notice to ORGANIZATION, terminate this AGREEMENT without further delay, whereupon ORGANIZATION shall vacate the PREMISES within fourteen calendar days. For a breach or default involving sanitary or safety conditions, the cure period is reduced to seven calendar days.
- b. CITY's Right to Cure. CITY at its sole discretion and with no obligation to do so, subject to any applicable conditions and limitations set forth elsewhere in this AGREEMENT, may, after a continuing breach or default by ORGANIZATION, perform or cause to be performed any of ORGANIZATION's unperformed obligations under this AGREEMENT. CITY may enter the PREMISES and remain there for the purpose of correcting or remedying the continuing breach or default. Such action by CITY shall not be deemed to waive or release said breach or any default or CITY's right to take further, preventative action.

**14. AGREEMENT NOTICES AND CONTACTS.** Any notice, request for consent, or statement ("NOTICE"), that RAP or ORGANIZATION is required or permitted to give or cause to be given to the other, shall be in writing and shall be delivered or addressed as set forth below. Either RAP or ORGANIZATION may designate a different address for any NOTICE by written statement to the other in accordance with the provisions of this Section. NOTICES shall be delivered personally or sent by confirmed facsimile transmission, by reliable courier providing tracking services, or by deposit with the United States Postal Service with postage prepaid and return receipt requested.

All NOTICES shall be addressed as follows:

ORGANIZATION: Friends of Banning Park Corporation  
Attn: Celina Swift, Manager of Operations  
P.O. Box 1927  
Wilmington, CA 90748  
(310) 548-7777  
brm\_cms@hotmail.com

CITY: City of Los Angeles Department of Recreation and Parks  
Attn: Partnerships Section  
221 N. Figueroa Street, Suite 180  
Los Angeles, CA 90012  
(213) 202-5600  
rap.partnerships@lacity.org

With a copy to: City of Los Angeles Department of Recreation and Parks  
Pacific Region  
Attn: Deanne Dedmon, Pacific Region Superintendent  
1670 Palos Verdes Dr. North  
Harbor City, CA 90710  
(310) 548-7643  
deanne.dedmon@lacity.org

**15. PROJECT NOTICES AND CONTACTS.** The following are the primary contacts for day to day PROJECT-related coordination and maintenance.

**Contact for ORGANIZATION:**

Friends of Banning Park Corporation  
Celina Swift, Manager of Operations  
brm\_cms@hotmail.com  
(310) 548-7777

**Contacts for RAP:**

Michael Sanborn, Banning Museum Director  
michael.sanborn@lacity.org  
(310) 548-7777

Kevin Reagan, Building Construction and Maintenance Superintendent  
kevin.reagan@lacity.org  
(213) 485-4802

Jason Winter, Plumber Supervisor  
jason.winter@lacity.org  
(310) 502-2616

Deanne Dedmon, Pacific Region Superintendent  
deanne.dedmon@lacity.org  
(310) 548-7643

Raul Leon, Maintenance Operations Superintendent, West and Pacific Regions  
raul.leon@lacity.org  
(213) 485-4810

**16. Representations and Warranties.** PARTIES each represents and warrants to the other that it has full power and authority to execute this AGREEMENT and to perform

its obligations and requirements hereunder. This AGREEMENT constitutes the valid and legal binding obligation of PARTIES, enforceable in accordance with its terms and conditions.

- 17. No Joint Venture or Agency Relationship.** Nothing herein contained shall be construed to place the PARTIES to this AGREEMENT in the relationship of a joint venture, association, partnership, or other form of a business organization or agency relationship. ORGANIZATION shall have no power to obligate or bind CITY in any manner whatsoever. Under no circumstances will the ORGANIZATION represent itself to be an agent of the CITY or any of its departments. Nothing in this AGREEMENT may be construed to have authorized or vested in ORGANIZATION the power to be an agent of the CITY or an actor under the color of law, be it civilly or criminally.
- 18. Relationship of Parties.** PARTIES agree that no other party shall have any right, power, or authority to assume, create, or incur any expense, liability, or obligation, expressed or implied, on behalf of any other party, except as expressly provided herein.
- 19. Safe Practices.** ORGANIZATION shall correct violations of safety practices during its PERMITTED USES immediately and shall cooperate fully and in good faith with CITY in the investigation of accidents or deaths occurring on the PREMISES. In the event of death or serious injury (requiring an emergency room hospital visit), ORGANIZATION must notify the RAP contacts referenced in Section 15 as soon as possible but no later than twenty-four hours after the incident by telephone call with a follow-up email notice. Notice of non-serious injuries occurring on the PREMISES shall be provided to RAP within seventy-two hours. ORGANIZATION shall keep internal documentation of the incident(s) during the previous two years and provide RAP with such information upon request.
- 20. Hazardous Substances and Environmental Sensitivity.** PARTIES agree that the PREMISES shall be used in a manner consistent with its intended public recreational purposes and within the scope of use set forth above. ORGANIZATION shall use the PREMISES in compliance with laws pertaining to hazardous substances and ensure that no pesticides, insecticides, herbicides and rodent poisons not in compliance with this Section are used on the PREMISES. As used herein, "hazardous substances" shall mean any product, chemical, material or waste whose nature, quantity and/or intensity of presence, use, manufacture, disposal, transportation, spill, release or effect, either by itself or in combination with other such substances, is either: (i) potentially injurious to public health, safety or welfare or injurious to the environment; (ii) regulated or monitored by any governmental authority; or (iii) a basis for liability of CITY or ORGANIZATION to any governmental agency or third party under applicable statute. No lead or oil-based paint, paint thinner, varnishes, lacquers and stain shall be brought onto or stored on the PREMISES.

ORGANIZATION must operate the PREMISES in an environmentally sensitive manner and must comply with RAP policies regarding protection of the environment.



ORGANIZATION shall not use or allow the use of environmentally unsafe products of any kind on the PREMISES.

**21. Ratification.** At the request of RAP, and because of the need therefore, ORGANIZATION may have begun performance of the responsibilities herein required prior to the execution hereof. By its execution hereof, RAP hereby accepts such services subject to all the terms, covenants, and conditions of this AGREEMENT, and ratifies its AGREEMENT with ORGANIZATION for such services.

**22. Incorporation of Documents.** This AGREEMENT and incorporated documents represent the entire integrated agreement of the PARTIES and supersedes all prior written or oral representations, discussions, and agreements. The following documents are incorporated and made a part hereof by reference.

EXHIBIT A: Site Plan

EXHIBIT B: Plans and Specifications

EXHIBIT C: Letter from Contractor

EXHIBIT D: Insurance Requirements and Instructions for Submission

In the event of any inconsistency between any of the provisions of this AGREEMENT and/or exhibits attached hereto, the inconsistency shall be resolved by giving precedence in the following order: (1) This AGREEMENT exclusive of attachments; (2) Exhibit A; (3) Exhibit B; (4) Exhibit C; and (5) Exhibit D.

**[SIGNATURE PAGE TO FOLLOW]**

IN WITNESS WHEREOF, the parties have executed this Agreement as of the day and year first above written.

**CITY:**

CITY OF LOS ANGELES, a municipal corporation, acting by and through its BOARD OF RECREATION AND PARK COMMISSIONERS

By signing below, the signatory attests that they have no personal, financial, beneficial, or familial interest in this Agreement.

By: \_\_\_\_\_  
President

By: \_\_\_\_\_  
Secretary

Date: \_\_\_\_\_

**ORGANIZATION:**

FRIENDS OF BANNING PARK CORPORATION, a 501(c)(3) nonprofit corporation

By: \_\_\_\_\_

Title: \_\_\_\_\_

By: \_\_\_\_\_

Title: \_\_\_\_\_

Date: \_\_\_\_\_

**APPROVED AS TO FORM:**

HYDEE FELDSTEIN SOTO, City Attorney

By: \_\_\_\_\_  
Brendan Kearns, Deputy City Attorney

Date: \_\_\_\_\_

## EXHIBIT A Site Plan

The Banning Museum, located at 401 East M Street, Wilmington, CA 90744, is depicted in the site map below. The area within the purple boundary is the location of the historic well.

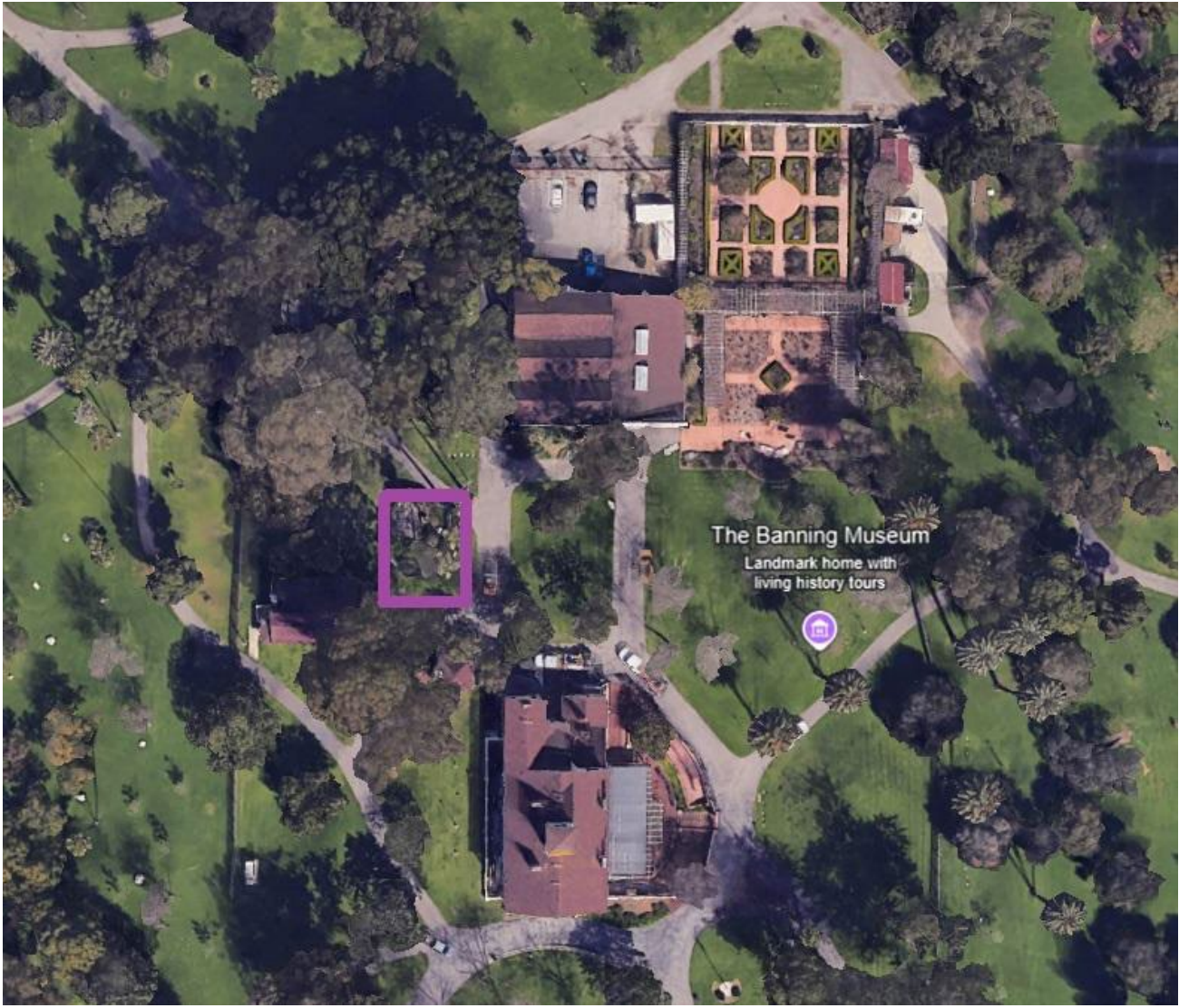

**EXHIBIT B**  
**Plans and Specifications**

**To be attached separately**

# BANNING MUSEUM HISTORIC WELL REHABILITATION



HISTORIC PHOTOGRAPHS

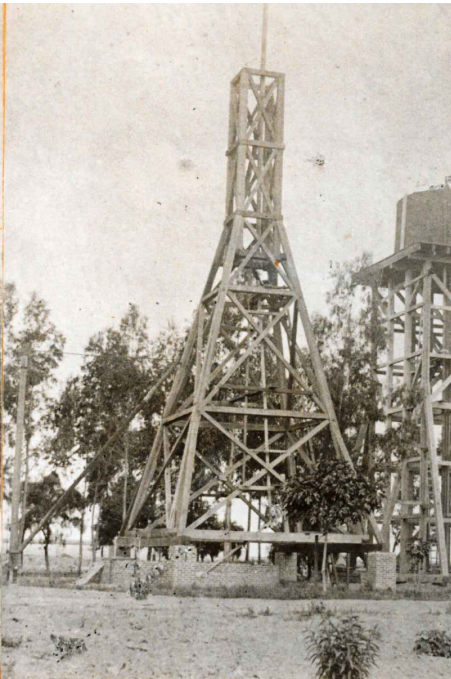
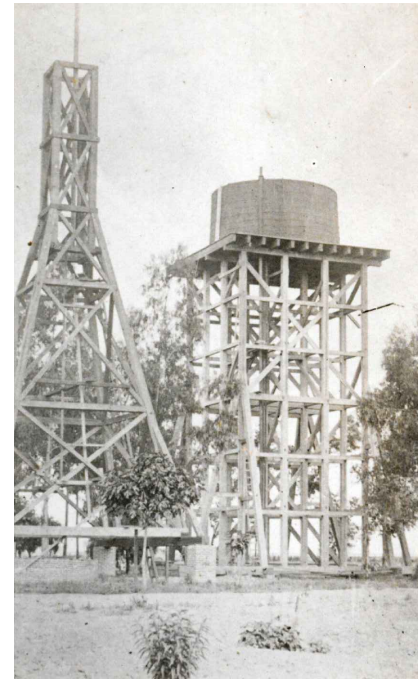
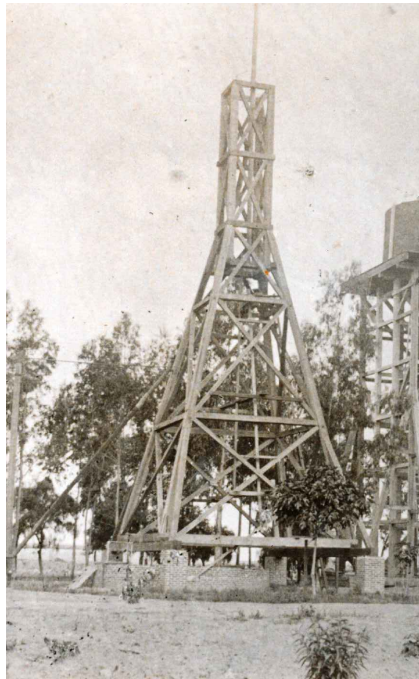

**BANNING  
MUSEUM  
HISTORIC WELL  
REHABILITATION**

401 E M ST,  
WILMINGTON, CA 90748

SPECTRA JOB NO. 109045

**LOCATION**

401 E M ST, WILMINGTON, CA 90744

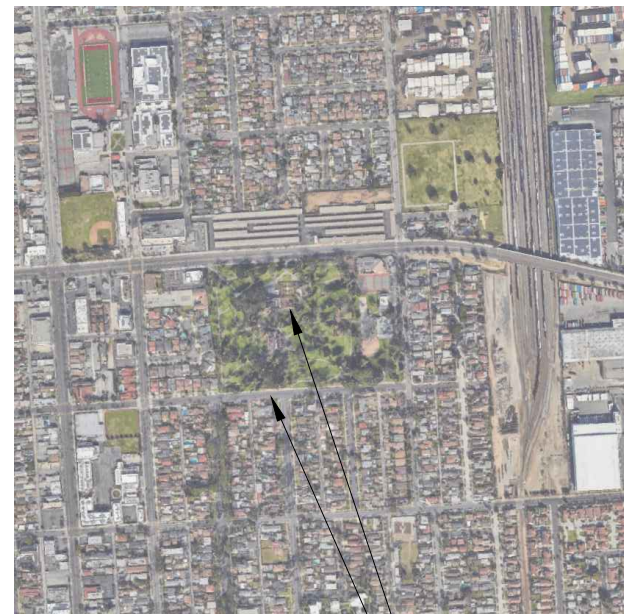

VICINITY MAP

PROJECT SITE  
M ST.

**PROJECT DIRECTORY**

**OWNER/DEVELOPER**  
CITY OF LOS ANGELES  
MICHAEL SANBORN, DIRECTOR  
BANNING MUSEUM  
(310) 548-7777  
MICHAEL.SANBORN@LACITY.ORG  
401 E M ST.  
WILMINGTON, CA 90748

**CONTRACTOR**  
DICK GEE  
SPECTRA COMPANY  
(562) 889-0215  
DGEE@SPECTRACOMPANY.COM  
2510 SUPPLY ST.  
POMONA, CA 91767

**SHEET INDEX**

- A-1 TITLE SHEET
- A-2 SITE PLAN
- A-3 EXISTING CONDITIONS PLAN & ELEVATIONS
- A-4 REHABILITATION PLAN & ELEVATION
- A-5 PARTIAL SITE & ACCESSIBLE PATH

**SCOPE OF WORK**

RESTORE DAMAGED EXISTING,  
NON-FUNCTIONAL HISTORIC WELL TO  
MATCH ORIGINAL HEIGHT, PROVIDE  
ACCESSIBLE PATH TO VIEW.

DRAWN BY: KT, RR  
CHECKED BY: DG

REVISIONS:  
A 8/25/23 CLIENT SUBMITTAL  
B 11/31/23 CLIENT RESUBMITTAL

TITLE SHEET

**A-1**



**SPECTRA**  
HISTORIC CONSTRUCTION

2510 Supply Street  
Pomona, CA 91767  
Phone: (800) 375-1771  
SpectraCompany.com

SUBCONTRACTOR/STAMP

**BANNING  
MUSEUM  
HISTORIC WELL  
REHABILITATION**

401 E M ST,  
WILMINGTON, CA 90748

SPECTRA JOB NO. 109045

DRAWN BY:	KT, RR	CHECKED BY:	DG
REVISIONS:			
A	8/25/23	CLIENT	SUBMITTAL
B	11/31/23	CLIENT	RESUBMITTAL

**SITE PLAN**

**A-2**

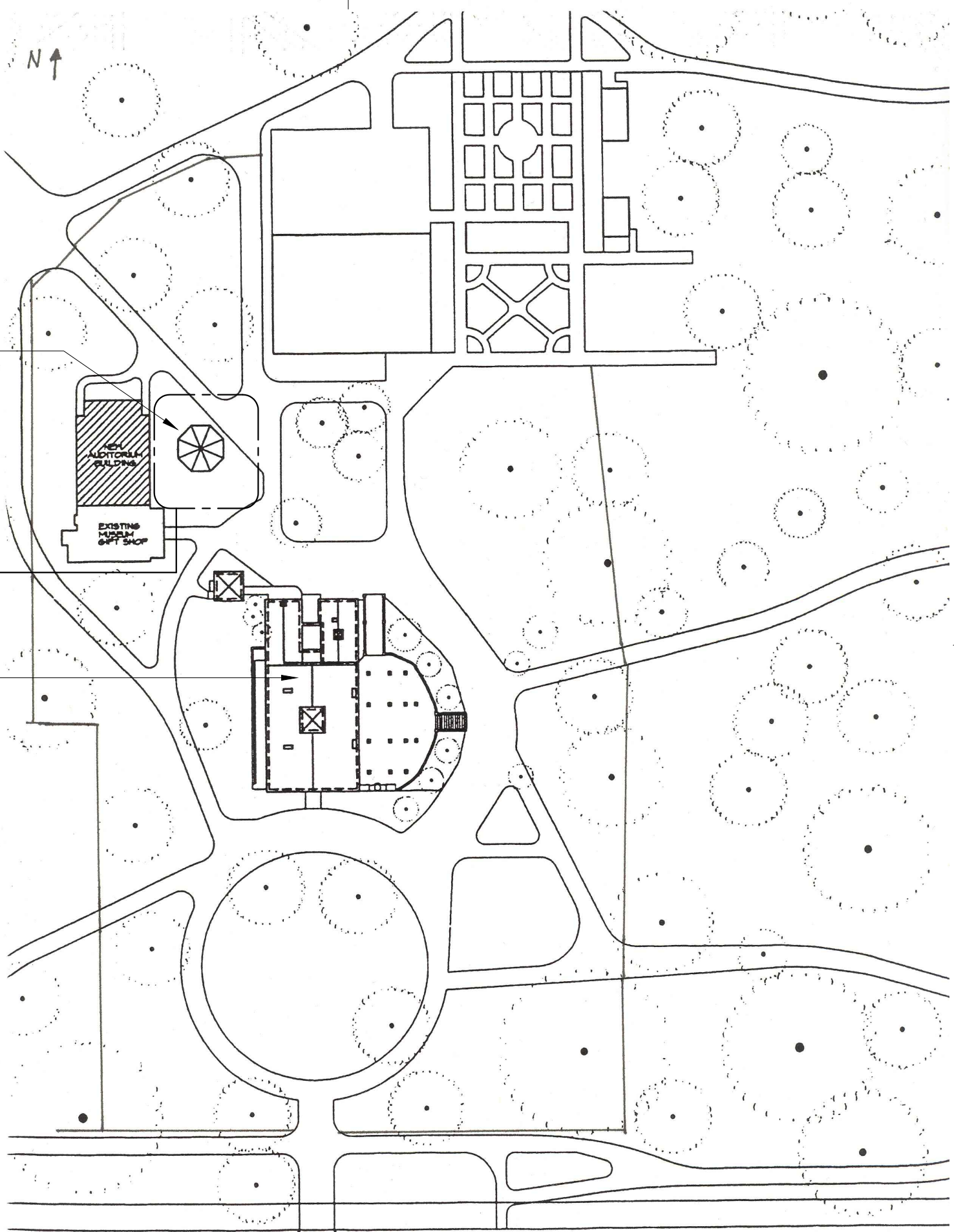

PROJECT SITE /  
HISTORIC WELL

1	1	1
A-3	A-4	A-5

BANNING  
MANSION

SITE PLAN

SCALE  
N.T.S.

1



EXISTING CONDITIONS

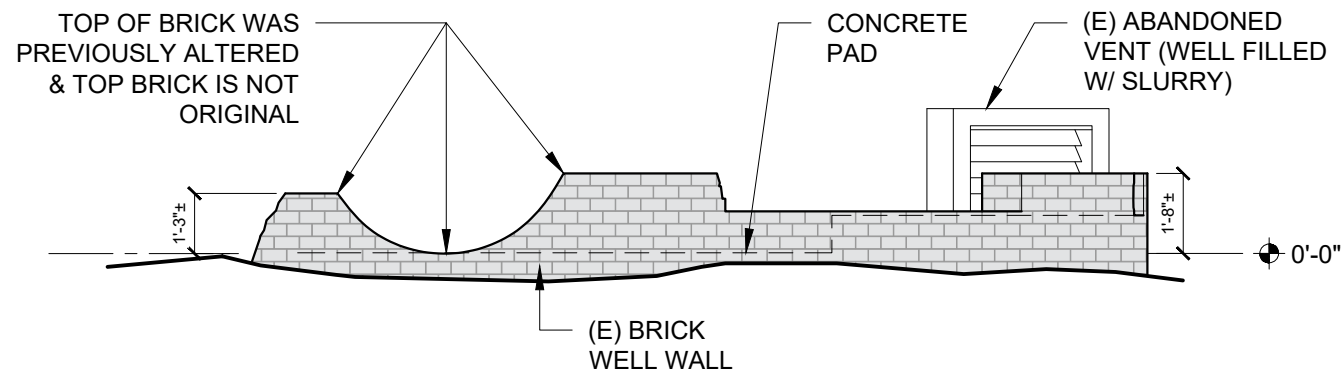

EXISTING CONDITIONS SOUTH ELEVATION

SCALE  
1/4" = 1'-0"

2

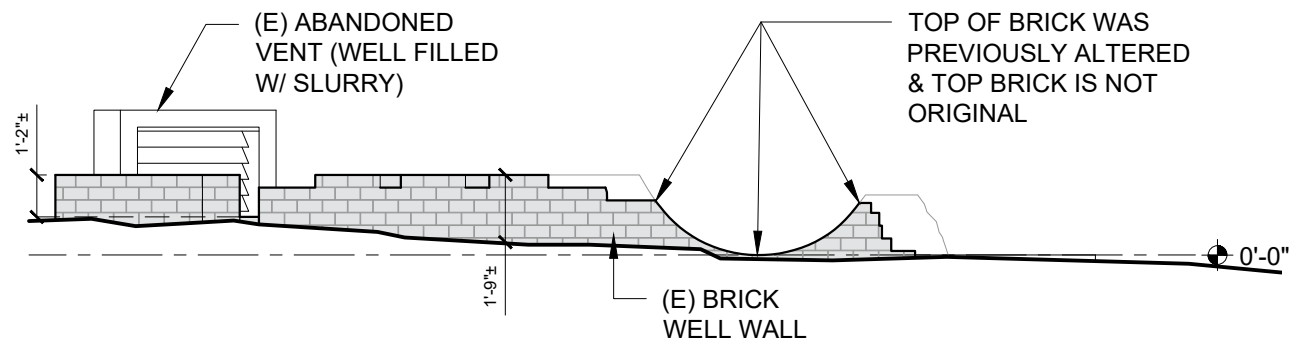

EXISTING CONDITIONS NORTH ELEVATION

SCALE  
1/4" = 1'-0"

3

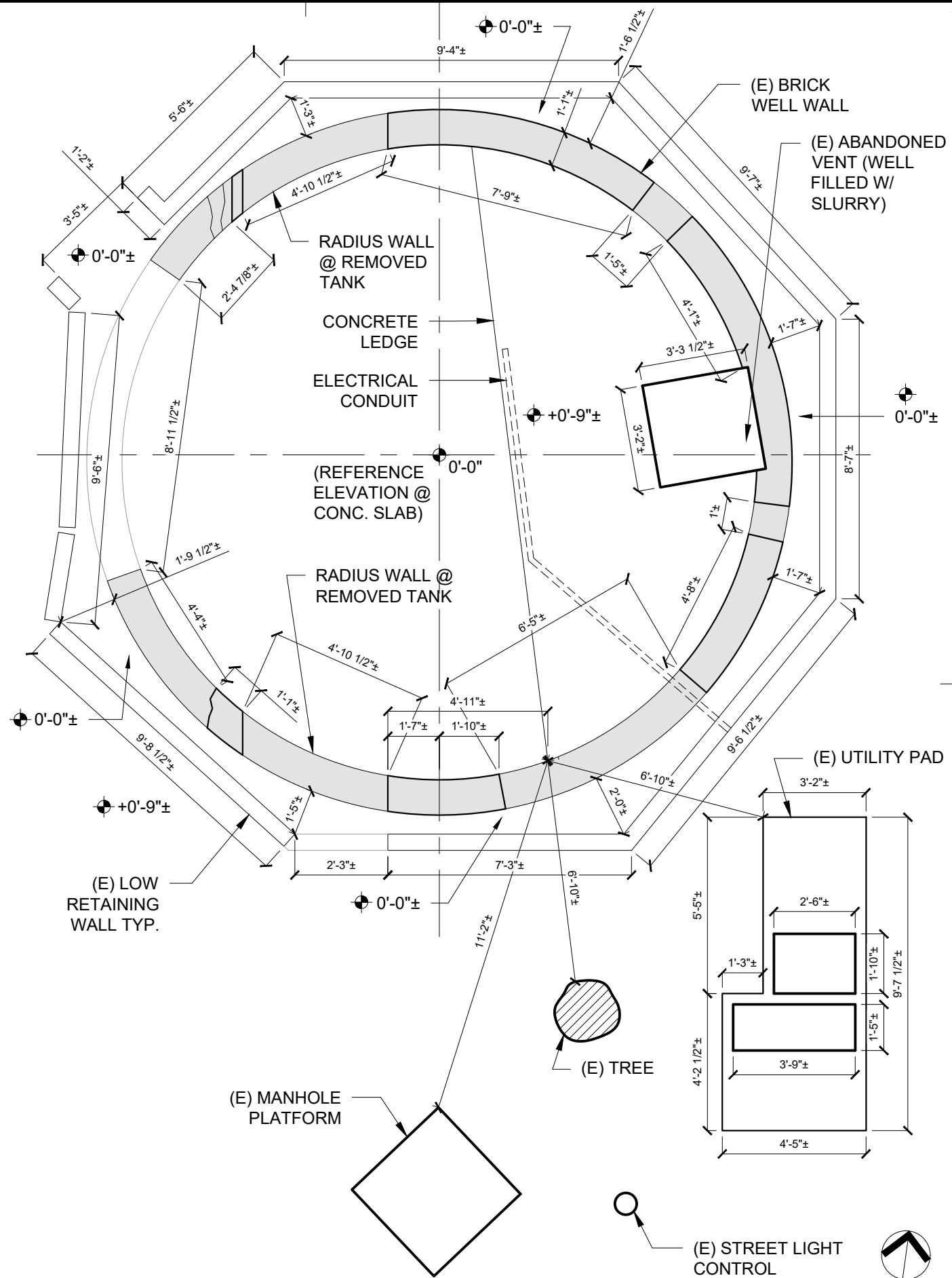

EXISTING CONDITIONS PLAN

SCALE  
1/4" = 1'-0"

1

SUBCONTRACTOR/STAMP

**BANNING MUSEUM  
HISTORIC WELL  
REHABILITATION**

401 E M ST,  
WILMINGTON, CA 90748

SPECTRA JOB NO. 109045

DRAWN BY:	KT, RR	CHECKED BY:	DG
REVISIONS:	A 8/25/23 CLIENT SUBMITTAL		
	B 11/31/23 CLIENT RESUBMITTAL		

**EXISTING CONDITIONS  
PLAN &  
ELEVATIONS**

**A-3**

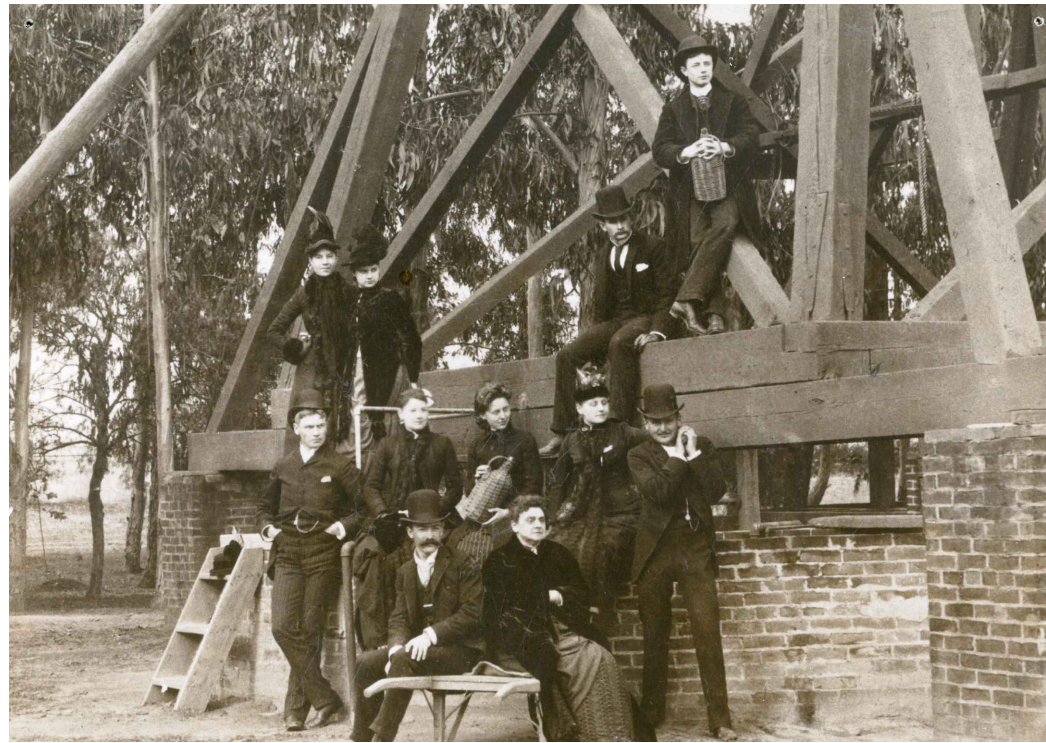

HISTORICAL WELL HEIGHT

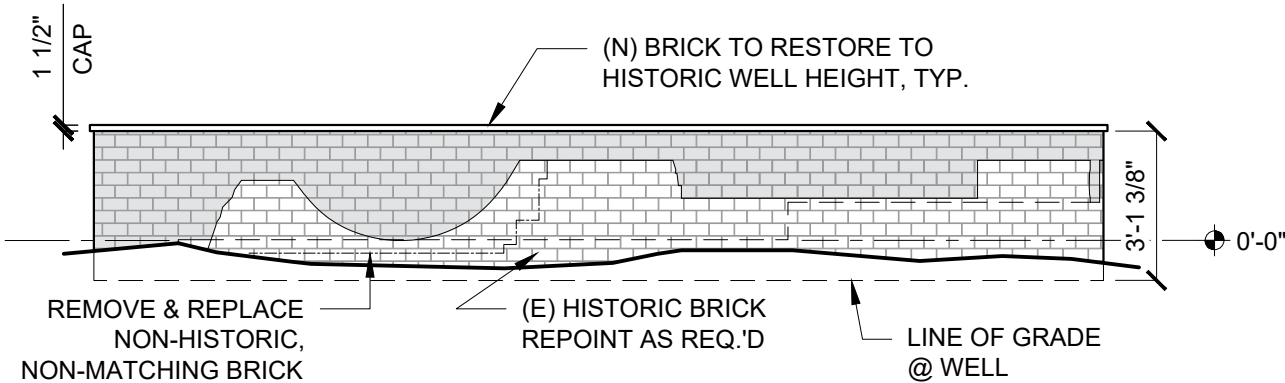

SOUTH ELEVATION

SCALE  
1/4" = 1'-0"

2

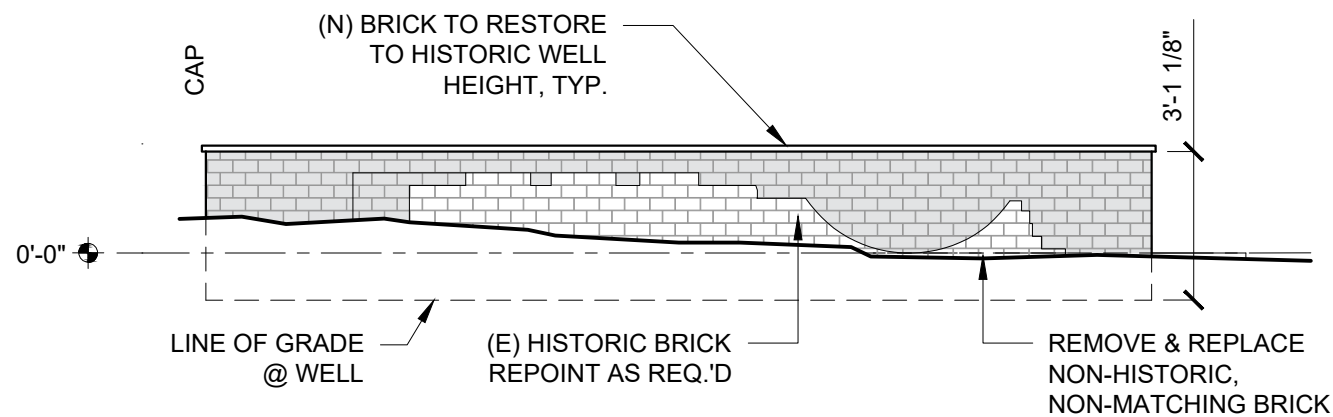

NORTH ELEVATION

SCALE  
1/4" = 1'-0"

3

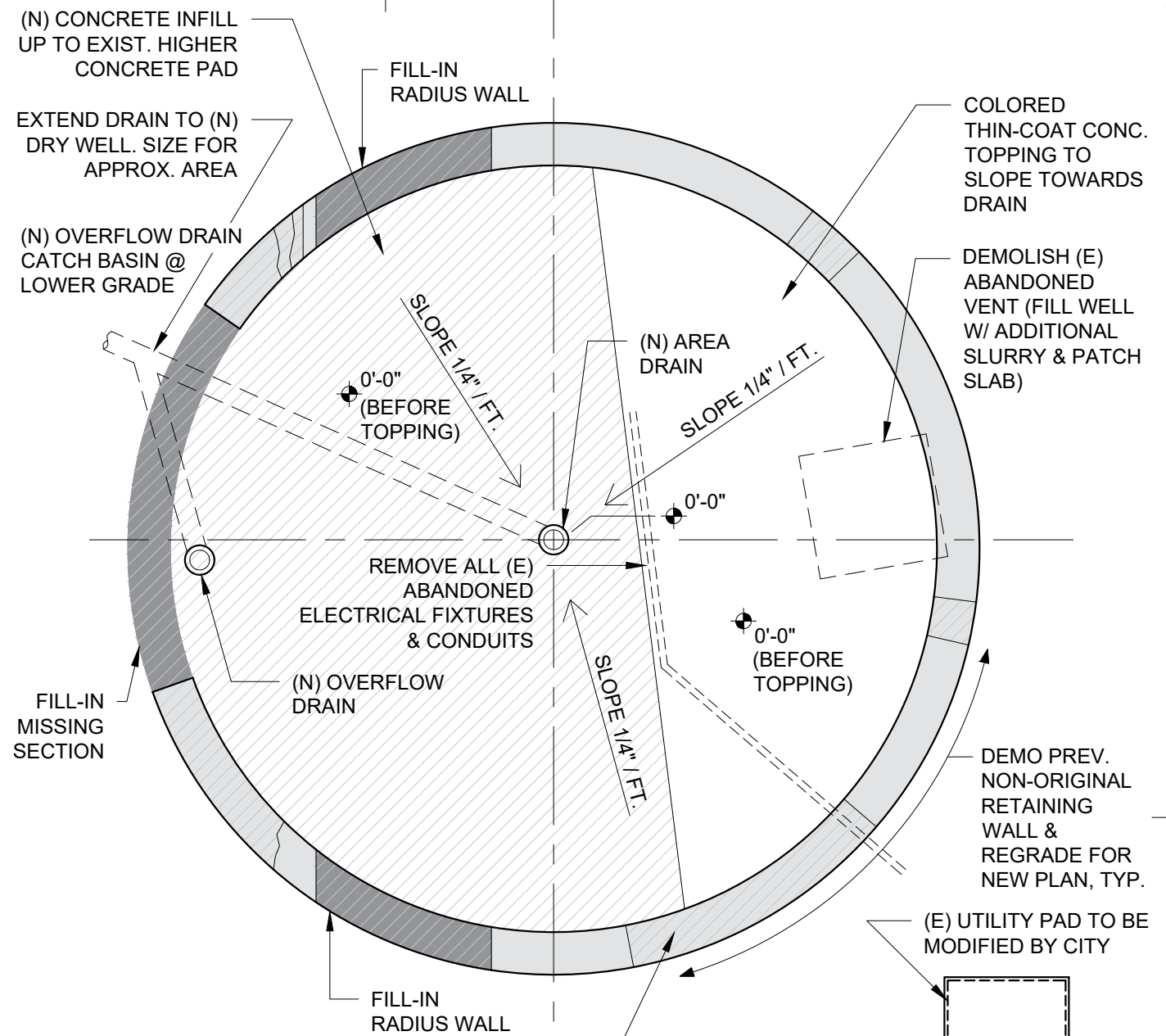

NOTES:

- (1) RESTORE (E) HISTORIC BRICK WELL WALL TO ORIGINAL HEIGHT. HISTORIC HEIGHT IS 14 BRICK COURSES PLUS BRICK WALL CAP. ALL ORIGINAL CAP WAS PREVIOUSLY REMOVED. TOP OF EXISTING WALL IS 9 COURSES; TOP COURSES ARE NOT ORIGINAL.
- (2) REMOVE ANY NON-ORIGINAL OR DETERIORATED BRICK.
- (3) MATCH HISTORIC BRICK AS CLOSE AS POSSIBLE IN DIMENSIONS, COLOR, & TEXTURE.
- (4) ANALYZE (E) MORTAR. ENSURE COMPATIBLE MORTAR MIX IN COLOR, AGGREGATE, HARDNESS, & TOOLING.
- (5) SEE SHEET A-5 FOR ADDITIONAL SITE WORK.

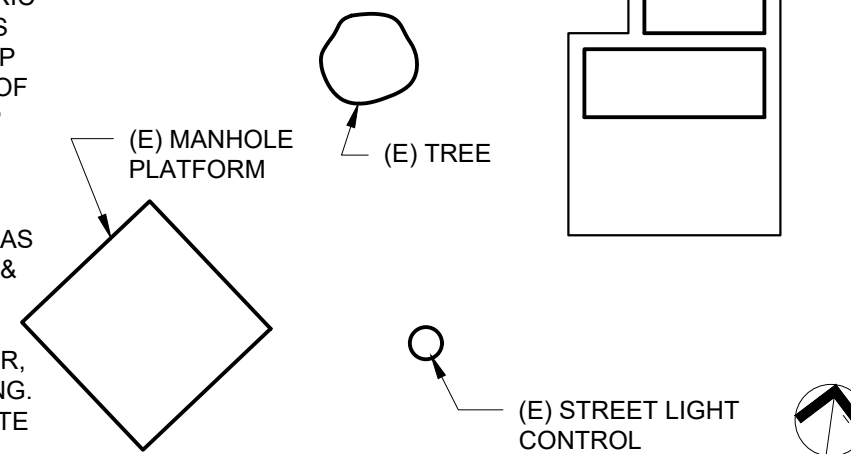

WELL REHABILITATION PLAN

SCALE  
1/4" = 1'-0"

1

**BANNING MUSEUM**  
HISTORIC WELL REHABILITATION

401 E M ST,  
WILMINGTON, CA 90748

SPECTRA JOB NO. 109045

DRAWN BY:	KT, RR	CHECKED BY:	DG
REVISIONS:			
A	8/25/23	CLIENT SUBMITTAL	
B	11/31/23	CLIENT RESUBMITTAL	

REHABILITATION PLAN & ELEVATIONS



**BANNING MUSEUM  
HISTORIC WELL  
REHABILITATION**

401 E M ST,  
WILMINGTON, CA 90748

SPECTRA JOB NO. 109045

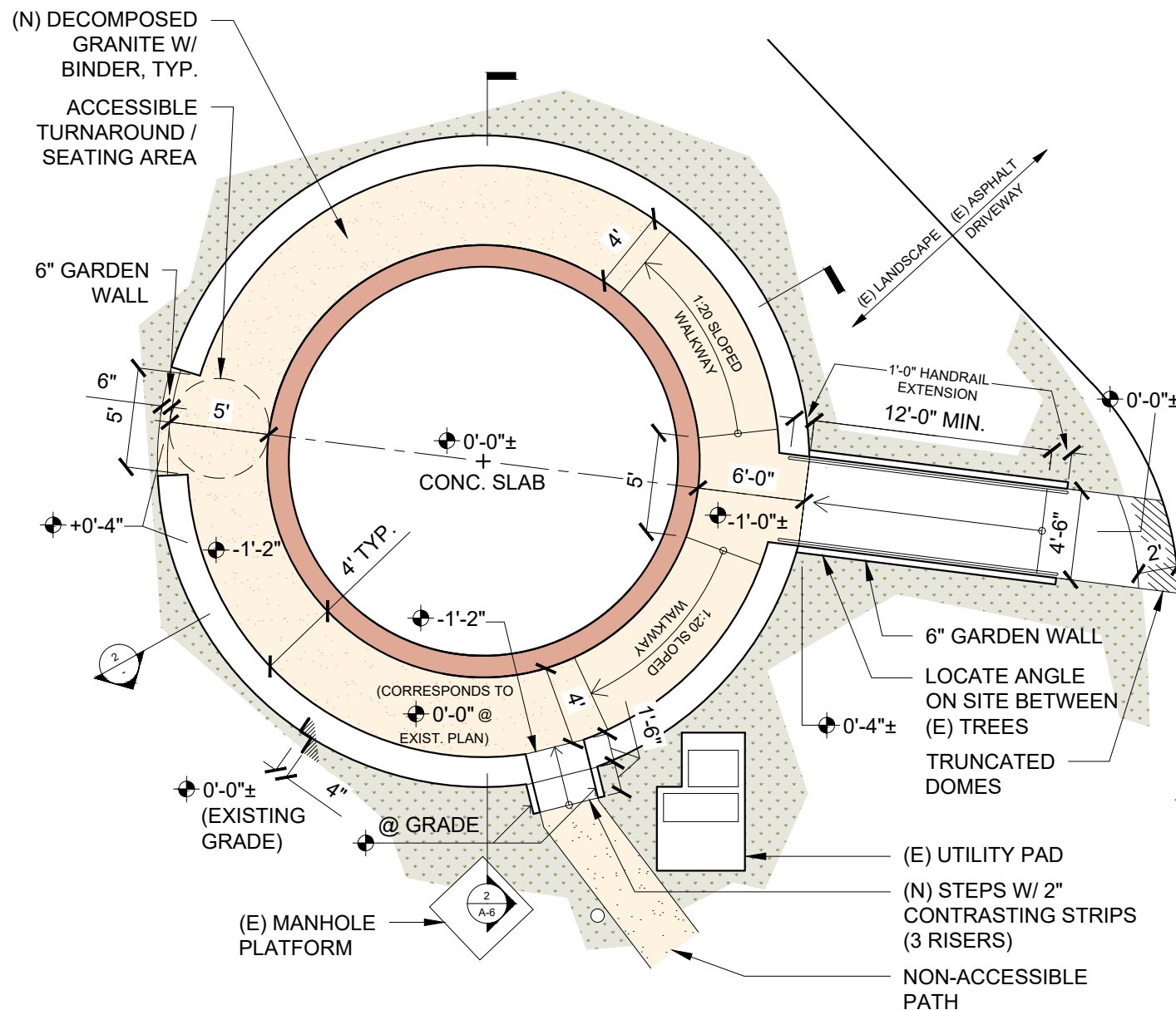

**5** SCALE 1/8" = 1'-0" **3**

PLAN SCALE 1/8" = 1'-0" **1**

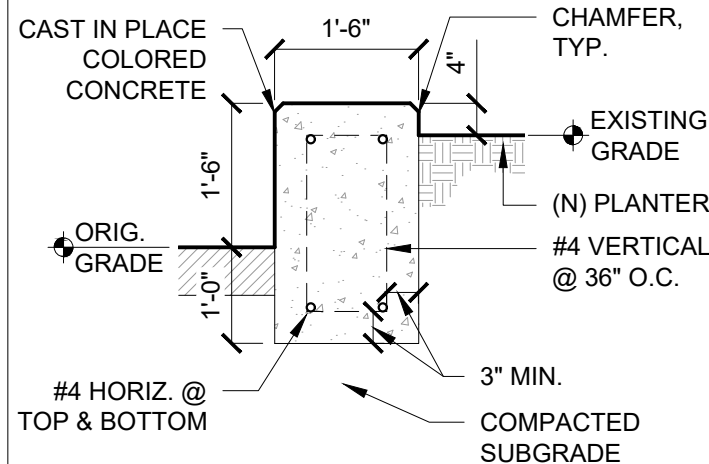

**6** SEAT WALL DETAIL SCALE 1/2" = 1'-0" **4**

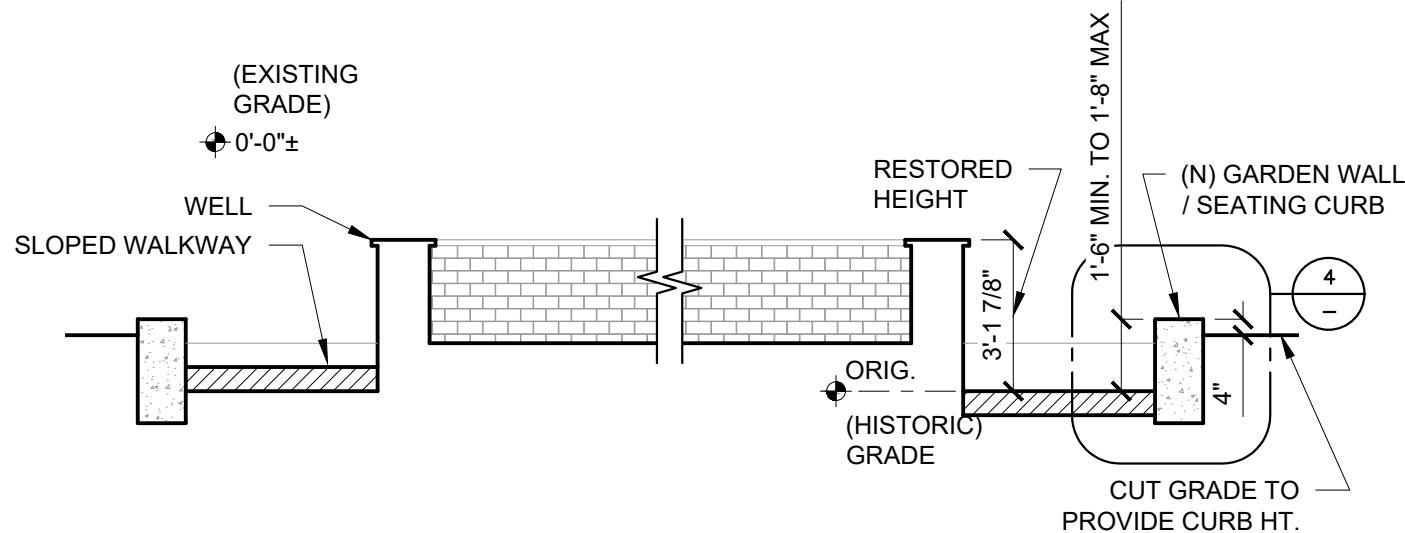

SECTION SCALE 1/4" = 1'-0" **2**

DRAWN BY: KT, RR  
CHECKED BY: DG

REVISIONS:

A	8/25/23	CLIENT SUBMITTAL
B	11/31/23	CLIENT RESUBMITTAL

**PARTIAL SITE  
& ACCESSIBLE  
PATH PLAN**

**A-5**

**Exhibit C**  
**Letter from Contractor**

**To be attached separately**



May 28, 2024

Elena Maggioni, Ph.D.  
Environmental Supervisor  
Department of Recreation and Parks  
221 N. Figueroa St., Room 400 MS 682  
Los Angeles, CA 90012  
e-mail: elena.maggioni@lacity.org

**RE: Banning Museum Historic Well Rehabilitation**

Dear Elena,

We previously met via Teams a few months ago and Michael Sanborn had reported that he confirmed with his city contacts that a building permit for the rehabilitation of the well was not required since it was a low structure not requiring a permit. You requested a letter to review the work in context of the Secretary of the Interior's Standards for Rehabilitation.

**Banning Residence Well - History**

(Received from Michael Sanborn, Director of Banning Museum)

In the early 1870s, Wilmington needed a steady water supply. Early provisions of water to the area had to be carted in, highly unfavorable among residents and deemed primitive and expensive. With the recent establishment of the Drum Barracks bringing in thousands of soldiers, the area's residents could no longer ignore their parched reality. The officers at the barracks made an early attempt to rectify this problem by digging a ditch and flume that was intended to flow from the San Gabriel River. While this endeavor was initially successful in bringing water to Wilmington, the surrounding farmers opposed as they used the same water source to irrigate their crops. The supply was quickly cut off and in considering the half a million dollars and amount of timber that was utilized to complete the flume, onlookers deemed the effort a "monument of folly" on behalf of the officers.

Phineas Banning was the next to take on the Wilmington's water problems. He proposed a well be dug in order to tap in to the water supply under the land's surface. The well would be dug on his own property, although it was the highest point in the town. He soon enacted plans for a massive 75 feet deep well that would utilize two steam engines during the process; one hoisted out the dirt, and one pumped out the necessary water.

This prospect of this well was a good sign for the future of the area and in fact, directly affected the plans for surrounding lands even early on. The government had recently relinquished the Drum Barracks near Banning's property back to Phineas Banning and Benjamin Davis Wilson when the Civil War ended. The success of the new well seemed so imminent to Banning and Wilson, that the two had plans to erect two more wells on the site of the old barracks so they could create a new park complete with shade trees, roses, shrubbery, and graveled walking paths. "No labor or expense will be spared to make these grounds, now so destitute of trees, the most attractive and lovely in Southern California," reported the Los Angeles Herald in 1873. This abundant new park, planned to be called Wilson's Park, is a perfect example of the amount of water that was expected to be brought to the area by the wells and

the untapped water source that lay beneath the surface. This well would go on to change the fortunes of a community.

The original well on Banning's property held the title of "largest well in California" when it was built, as the structure was 25 feet in diameter and 40 feet deep, although it hit water at 35 feet. Even at this point in 1882, the well was not yet complete with the plans still calling to get the well to 70 feet deep. The logistic of the well included a large wooden tank within the well that flared out of the bottom where the water entered and was then pumped into a giant elevated tank to be collected and sent to the surrounding areas. The whole venture cost a reported \$8,000 - \$10,000.

In its time, the well was a giant success for Phineas Banning, Wilmington, and San Pedro. The new water supply, connecting reservoir, and tanks were seen as a "permanent monument of progress." Moving away from the previous water carts was a blessing for the area and residents approved of the new well water calling it inexhaustible and first-rate quality. Between three tanks that helped move the water supply out to San Pedro there was a nearly 200,000-gallon capacity. Connecting these apparatuses was a 3-inch iron pipe that spread 4 miles providing water to Banning's homestead, all of Wilmington and San Pedro, as well as those lived along the pipeline. Overall, the well had a capacity of yielding 500,000 gallons of water daily, solving the water supply issues that plagued the area for years.

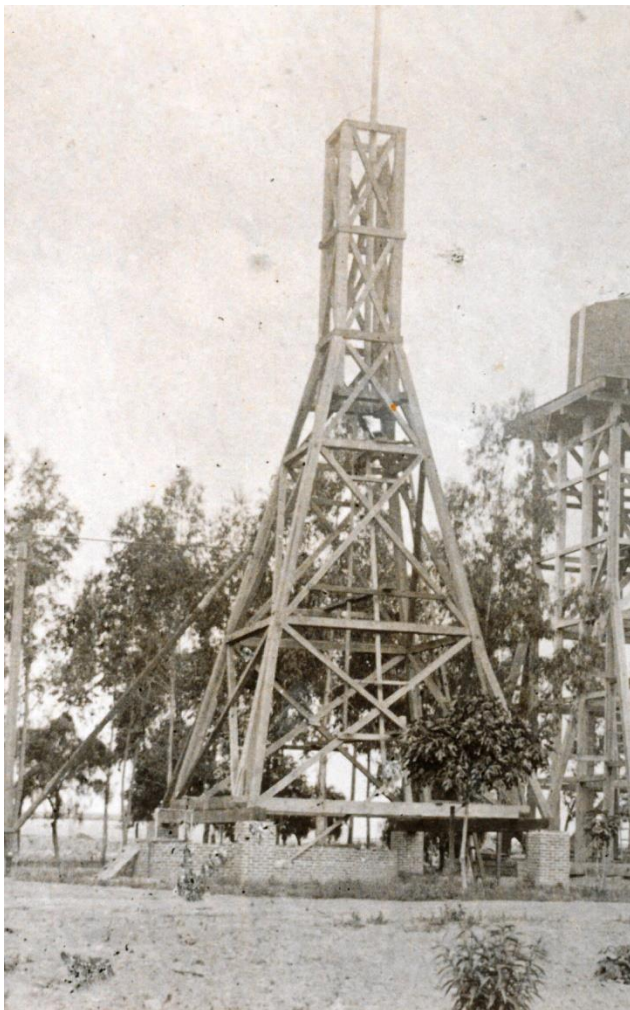

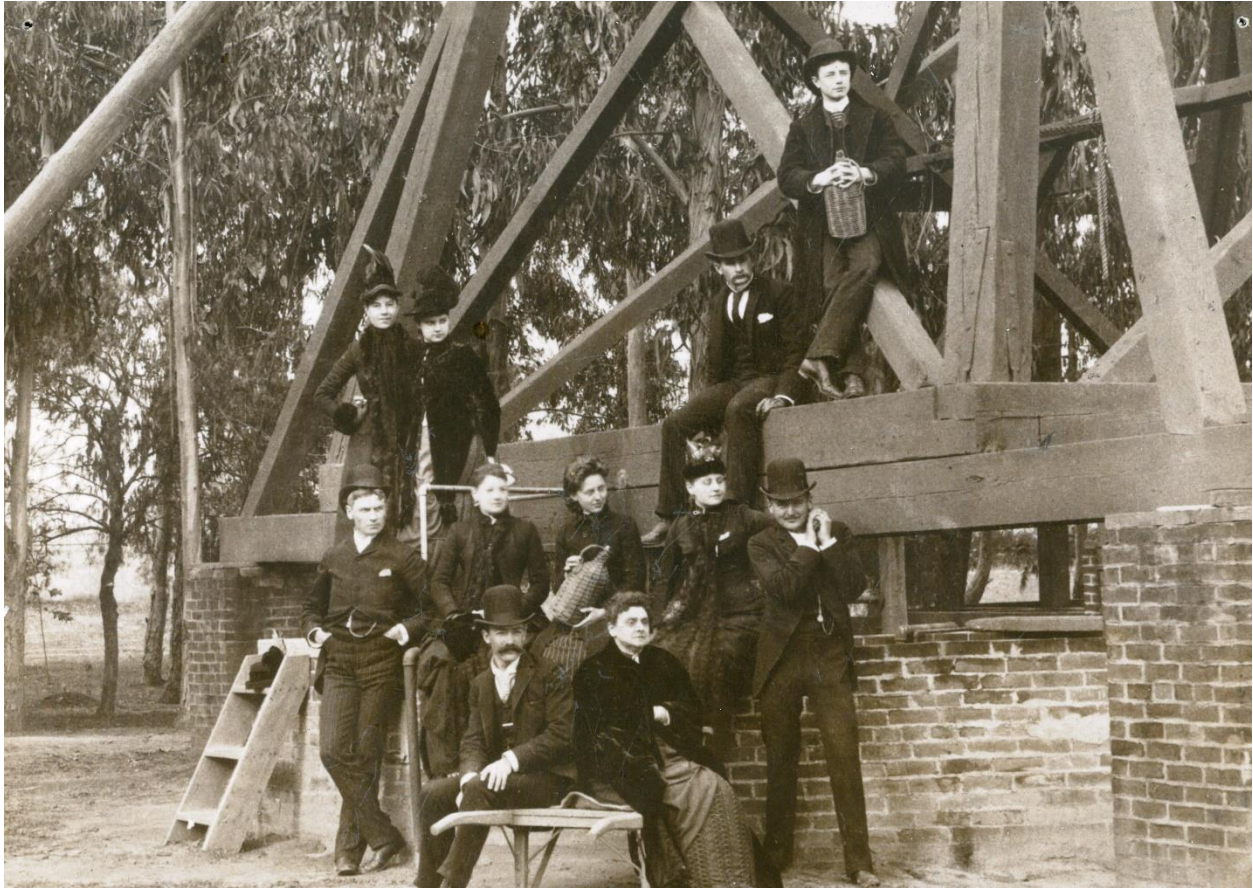

**Banning Residence Well – Character Defining Features and Condition**

<u>Character-Defining Feature</u>	<u>Description</u>	<u>Condition</u>
Massing	Low, circular well wall	Circular plan is intact. Original tall tower has been lost a long time.
Brick Wall	Low height red brick wall with flush joints	Poor- a portion of the wall is missing. Many bricks, especially the top course(s) are not original.
Setting	Open, landscaped setting on flat site.	Setting largely remains intact except that the original grade has been raised approximately 9". The original open well has been filled/covered with concrete a long time.



### **Banning Residence Well – Treatment Plan**

The original brick wall will be restored and missing portions of the wall will be replaced in kind to match as close as possible to the color and dimensions to the original. Historic photographs show a brick top cap that is missing which will be restored.

Within the well, a later vent addition will be removed and the stepped concrete infill will be leveled smooth to eliminate the step. A four (4) foot wide area around the perimeter of the well will be excavated around the well to restore the original grade for enough width to view the entire elevation of the well wall and to partially restore the original setting. This will be retained by a bench retaining wall and a ramp and steps added for access to allow for seating that will be used for an educational opportunity.

Preserving all of the original extant materials, restoring the historic height of the wall and restoring the original grade around the near perimeter of the well wall will restore much more of the character of the original well wall and conform to the Secretary of the Interior's Standards for Rehabilitation.

If you have any questions, please do not hesitate to contact me.

Dick Gee, AIA  
Architect/Project Manager

(562) 889-0215  
[dgee@spectracompany.com](mailto:dgee@spectracompany.com)

cc: Michael Sanborn, Director, Banning Museum

## EXHIBIT D Insurance Requirements

Form Gen. 146 (Rev. 6/12v)

### Required Insurance and Minimum Limits

Name: Friends of Banning Museum Date: 10/11/2024

Agreement/Reference: Agreement for the Rehabilitation of the Banning Museum Historic Well

Evidence of coverages checked below, with the specified minimum limits, must be submitted and approved prior to occupancy/start of operations. Amounts shown are Combined Single Limits ("CSLs"). For Automobile Liability, split limits may be substituted for a CSL if the total per occurrence equals or exceeds the CSL amount.

	Limits
<input checked="" type="checkbox"/> <b>Workers' Compensation (WC) and Employer's Liability (EL)</b>	WC <u>Statutory</u> EL <u>\$ 1,000,000</u>
<input checked="" type="checkbox"/> Waiver of Subrogation in favor of City <input type="checkbox"/> Longshore & Harbor Workers <input type="checkbox"/> Jones Act	
<input checked="" type="checkbox"/> <b>General Liability</b> <u>City of Los Angeles must be named as an additional insured party</u>	<u>\$ 1,000,000</u>
<input checked="" type="checkbox"/> Products/Completed Operations <input type="checkbox"/> Sexual Misconduct _____ <input type="checkbox"/> Fire Legal Liability _____ <input checked="" type="checkbox"/> \$3,000,000 aggregate	
<input checked="" type="checkbox"/> <b>Automobile Liability</b> (for any and all vehicles used for this contract, other than commuting to/from work)	<u>1,000,000</u>
<input type="checkbox"/> <b>Professional Liability</b> (Errors and Omissions)	_____
Discovery Period <u>12 months after completion of work or date of termination</u>	
<input type="checkbox"/> <b>Property Insurance</b> (to cover replacement cost of building - as determined by insurance company)	_____
<input type="checkbox"/> All Risk Coverage <input type="checkbox"/> Boiler and Machinery <input type="checkbox"/> Flood _____ <input type="checkbox"/> Builder's Risk <input type="checkbox"/> Earthquake _____ <input type="checkbox"/> _____	
<input type="checkbox"/> _____	_____
<input type="checkbox"/> _____	_____
<input checked="" type="checkbox"/> _____	_____
<input type="checkbox"/> <b>Surety Bonds - Performance and Payment (Labor and Materials) Bonds</b>	_____
<input type="checkbox"/> <b>Crime Insurance</b>	_____

Other: Provided to: Priya Macwan

If a contractor has no employees and decides to not cover herself/himself for workers' compensation, please complete the form entitled "Request for Waiver of Workers' Compensation Insurance Requirement" located at: <http://cao.lacity.org/risk/InsuranceForms.htm>.

In the absence of imposed auto liability requirements, all contractors using vehicles during the course of their contract must adhere to the financial responsibility laws of the State of California.

CITY OF LOS ANGELES

INSTRUCTIONS AND INFORMATION  
ON COMPLYING WITH CITY INSURANCE REQUIREMENTS

(Share this information with your insurance agent or broker)

1. **Agreement/Reference** All evidence of insurance should identify the nature of your business with the CITY. Clearly show any assigned number of a bid, contract, lease, permit, etc. or give the project name and the job site or street address to ensure that your submission will be properly credited. Provide the **types of coverage and minimum dollar amounts** specified on the Required Insurance and Minimum Limits sheet (Form Gen. 146) included in your CITY documents.

2. **When to Submit** Normally, no work may begin until a CITY insurance certificate approval number ("CA number") has been obtained, so insurance documents should be submitted as early as practicable. For **As-needed Contracts**, insurance need not be submitted until a specific job has been awarded. **Design Professionals** coverage for new construction work may be submitted simultaneously with final plans and drawings, but before construction commences.

3. **Acceptable Evidence and Approval** Electronic submission is the required method of submitting your documents. **KwikComply** is the CITY's online insurance compliance system and is designed to make the experience of submitting and retrieving insurance information quick and easy. The system is designed to be used by insurance brokers and agents as they submit client insurance certificates directly to the City. It uses the standard insurance industry form known as the **ACORD 25 Certificate of Liability Insurance** in electronic format. **KwikComply** advantages include standardized, universally accepted forms, paperless approval transactions (24 hours, 7 days per week), and security checks and balances. The easiest and quickest way to obtain approval of your insurance is to have your insurance broker or agent access **KwikComply** at <https://kwikcomply.org/> and follow the instructions to register and submit the appropriate proof of insurance on your behalf.

**Contractor must provide City** a thirty (30) day notice of cancellation (ten (10) days for non-payment of premium) AND an Additional Insured Endorsement naming the CITY an additional insured completed by your insurance company or its designee. If the policy includes an automatic or blanket additional insured endorsement, the Certificate must state the CITY is an automatic or blanket additional insured. An endorsement naming the CITY an Additional Named Insured and Loss Payee as Its Interests May Appear is required on property policies. All evidence of insurance must be authorized by a person with authority to bind coverage, whether that is the authorized agent/broker or insurance underwriter.

Additional Insured Endorsements DO NOT apply to the following:

- Indication of compliance with statute, such as Workers' Compensation Law.
- Professional Liability insurance.

Verification of approved insurance and bonds may be obtained by checking **KwikComply**, the CITY's online insurance compliance system, at <https://kwikcomply.org/>.

4. **Renewal** When an existing policy is renewed, have your insurance broker or agent submit a new Acord 25 Certificate or edit the existing Acord 25 Certificate through **KwikComply** at <https://kwikcomply.org/>.

5. **Alternative Programs/Self-Insurance** Risk financing mechanisms such as Risk Retention Groups, Risk Purchasing Groups, off-shore carriers, captive insurance programs and self-insurance programs are subject to separate approval after the CITY has reviewed the relevant audited financial statements. To initiate a review of your program, you should complete the



Applicant's Declaration of Self Insurance form (<http://cao.lacity.org/risk/InsuranceForms.htm>) to the Office of the City Administrative Officer, Risk Management for consideration.

6. **General Liability** insurance covering your operations (and products, where applicable) is required whenever the CITY is at risk of third-party claims which may arise out of your work or your presence or special event on City premises. **Sexual Misconduct** coverage is a required coverage when the work performed involves minors. **Fire Legal Liability** is required for persons occupying a portion of CITY premises. Information on two CITY insurance programs, the SPARTA program, an optional source of low-cost insurance which meets the most minimum requirements, and the Special Events Liability Insurance Program, which provides liability coverage for short-term special events on CITY premises or streets, is available at ([www.2sparta.com](http://www.2sparta.com)), or by calling (800) 420-0555.

7. **Automobile Liability** insurance is required only when vehicles are used in performing the work of your Contract or when they are driven off-road on CITY premises; it is not required for simple commuting unless CITY is paying mileage. However, compliance with California law requiring auto liability insurance is a contractual requirement.

8. **Errors and Omissions** coverage will be specified on a project-by-project basis if you are working as a licensed or other professional. The length of the claims discovery period required will vary with the circumstances of the individual job.

9. **Workers' Compensation and Employer's Liability** insurance are not required for single-person contractors. However, under state law these coverages (or a copy of the state's Consent To Self Insure) must be provided if you have any employees at any time during the period of this contract. Contractors with no employees must complete a Request for Waiver of Workers' Compensation Insurance Requirement (<http://cao.lacity.org/risk/InsuranceForms.htm>). A **Waiver of Subrogation** on the coverage is required only for jobs where your employees are working on CITY premises under hazardous conditions, e.g., uneven terrain, scaffolding, caustic chemicals, toxic materials, power tools, etc. The Waiver of Subrogation waives the insurer's right to recover (from the CITY) any workers' compensation paid to an injured employee of the contractor.

10. **Property** Insurance is required for persons having exclusive use of premises or equipment owned or controlled by the CITY. **Builder's Risk/Course of Construction** is required during construction projects and should include building materials in transit and stored at the project site.

11. **Surety** coverage may be required to guarantee performance of work and payment to vendors and suppliers. A **Crime Policy** may be required to handle CITY funds or securities, and under certain other conditions. **Specialty coverages** may be needed for certain operations. For assistance in obtaining the CITY required bid, performance and payment surety bonds, please see the City of Los Angeles Contractor Development and Bond Assistance Program website address at <http://cao.lacity.org/risk/BondAssistanceProgram.pdf> or call (213) 258-3000 for more information.

12. **Cyber Liability & Privacy** coverage may be required to cover technology services or products for both liability and property losses that may result when a CITY contractor engages in various electronic activities, such as selling on the Internet or collecting data within its internal electronic network. Contractor's policies shall cover liability for a data breach in which the CITY employees' and/or CITY customers' confidential or personal information, such as but not limited to, Social Security or credit card information are exposed or stolen by a hacker or other criminal who has gained access to the CITY's or contractor's electronic network. The policies shall cover a variety of expenses associated with data breaches, including: notification costs, credit monitoring, costs to defend claims by state regulators, fines and penalties, and loss resulting from identity theft. The policies are required to cover liability arising from website media content, as well as property exposures from: (a) business interruption, (b) data loss/destruction, (c) computer fraud, (d) funds transfer loss, and (e) cyber extortion.